

# AIR TRACK SUPPLY

## JOINTAIR® 1101

ATS "C" type with JOINTAIR® 1101 which automatically draw the yarn ends to be spliced



## JOINTAIR® 4941A

ATS "L" type with JOINTAIR® 4941A on a sliding bar with swivel joint enabling splicer vertical movement on the tyre cord creel.



## JOINTAIR® 1401

ATS "C" type carrying JOINTAIR® 1401 on heating machine for carpet yarn.



## JOINTAIR® 116

ATS "C" type carrying JOINTAIR® 116 on a cable corder for carpet yarn.



## ILLMAN SPLICER

ATS with ILLMAN SPLICER on winder for carpet yarn.



## JOINTAIR® 124

ATS "L" type with JOINTAIR® 124 on winder processing industrial yarns.

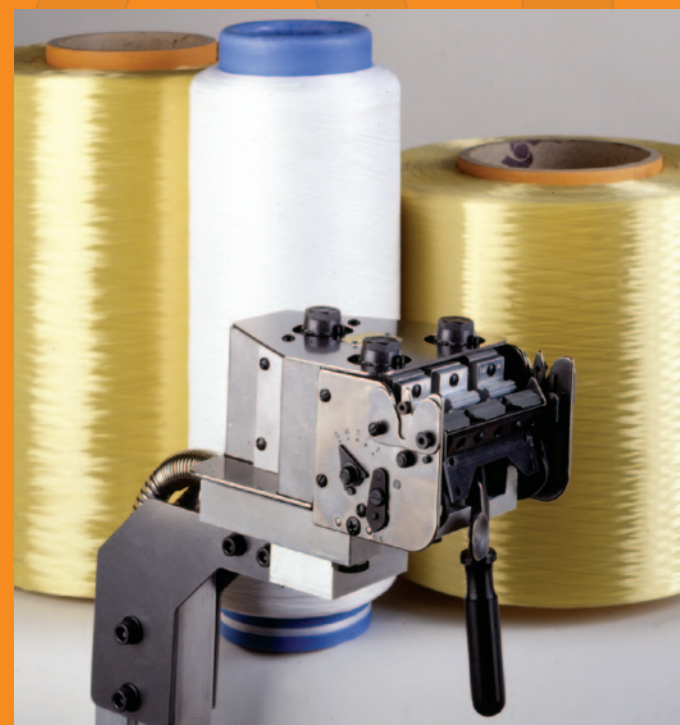

## JOINTAIR®124

Specifically developed for aramid and industrial yarn where very strong joints are required.

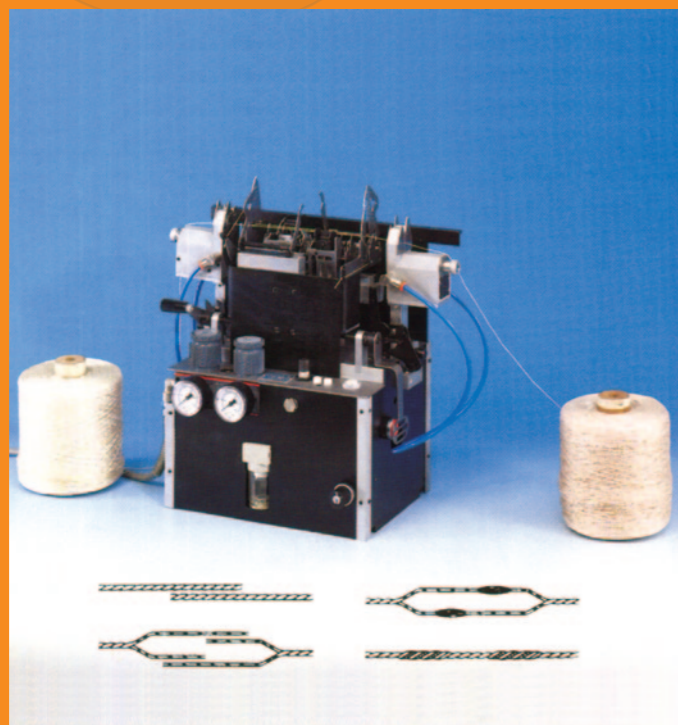

## JOINTAIR EPI code 385

JOINTAIR EPI code 385 to separately join each ply of a two ply tyre cord.



## JOINTAIR® 110R

ATS "C" type with JOINTAIR® 110R on a cable corder.



## JOINTAIR® 110R

ATS "C" type with JOINTAIR® 110R and vertically movable arm on texturizing machine creel.



## JOINTAIR® 115

ATS "C" type with JOINTAIR® 115 on embroidery machine.



## JOINTAIR® 115

Fitted on fixed position every two heads to splice silk spun yarn.



## JOINTAIR®4941A

ATS "L" type with JOINTAIR® 4941A on finish winder processing sewing threads.



## JOINTAIR®4941A

ATS "L" type fitting JOINTAIR® 4941A on finishing winder processing sewing threads.

A.T.S. is a COMPLETE system composed by rails, hoses, trolley, air filter & manometer, couplings, etc. enabling a yarn splicer to be operated and positioned at any desired area, thus matching in the best possible way operator's convenience as well as efficiency requirements. Thanks to a variety of standard ATS fixing brackets and splicer supports, it can be easily installed in the optimum working position, leaving both hands free for yarn manipulation, thus increasing productivity.

#### ATS "C" TYPE

This is the basic model, ideal for lightweight splicers like 115, 110R, 116 and 1401.

#### ATS "L" TYPE

A reinforced model suitable for heavier splicers such as 1101, 124, 4941A, etc.

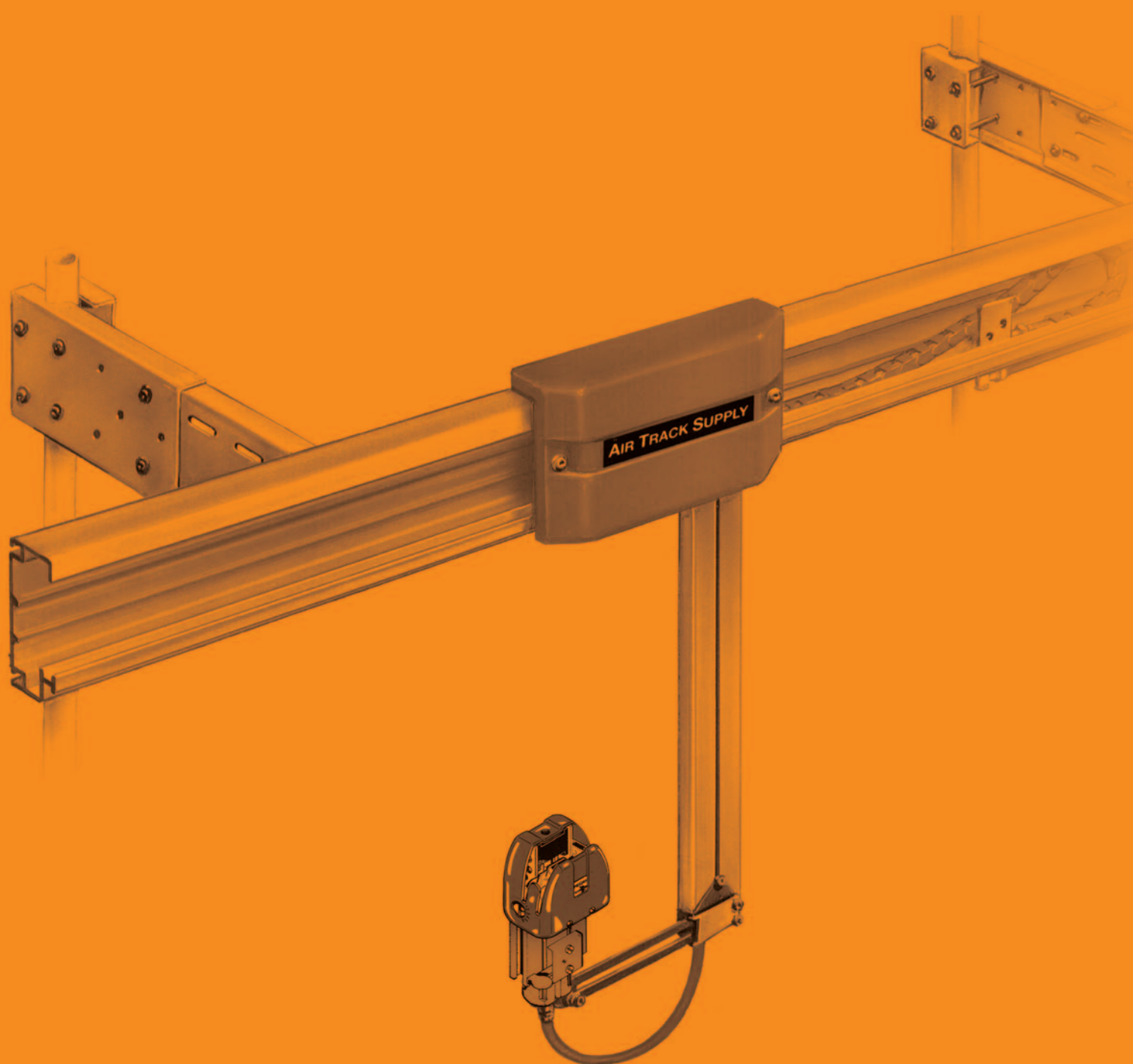

## RANGE OF SPLICERS FOR FILAMENT AND INDUSTRIAL YARNS

JOINTAIR® 110M-110R	For fine and delicate filament yarns	Dtex 20 – 4000
JOINTAIR® 114-115	For plied filament or spun yarns (i.e. embroidery yarns) and spun silk	Tex 6 – 150
JOINTAIR® 1401	For tail to top joining, mainly on tufting creel	Tex 100 – 3500
JOINTAIR® 116	Coarse count yarns, mainly for carpets	Tex 200 – 3000
JOINTAIR® 116K	For medium coarse count filament yarns	Tex 200 – 3500
JOINTAIR® 116G	For filament rovings and coarse industrial yarns	Tex 1000-5000
JOINTAIR® 1101	For P.O.Y. yarns for texturizing process	Dtex 20 – 1000
JOINTAIR® 4941A	For synthetic sewing threads and tyre cord	Tex 10 – 200
JOINTAIR® 124	For aramid yarns and carbon, glass fibre yarns	Tex 100 – 900
EPI 385	For tyre cord two ply yarns	Tex 200 – 800
ILLMAN 101 - 103	For yarns impossible to splice by mean of pneumatic splicers	Up to Ø 4,5 mm of yarn/material



**HAND OPERATED SPLICERS  
FOR KNOTFREE YARNS**  
filament, industrial yarns  
and sewing threads

Mesdan, a recognised leader in yarn joining since 1952, are able to achieve knotfree joining at almost every stage of textile processing by means of a variety of splicing technologies, such as JOINTAIR®, AQUASPLICER® and HOT JOINTAIR®. Practical and convenient solutions by using the A.T.S. (Air Truck Supply) system are available for all kinds of machines or creels where yarn joining is necessary.

#### JOINTAIR®, AQUASPLICER®, HOT JOINTAIR® AND MOISTAIR® FITTED ON AUTOMATIC WINDERS.

Mesdan yarn splicers, featured as standard equipment by several automatic winders manufacturers, are also supplied directly to the end user for RETROFITTING on existing winders, to replace old models of splicers and optimise yarn joining quality. Transformation kits are available for various automatic winders.

#### JOINTAIR®, AQUASPLICER®, HOT JOINTAIR® FOR A.T.S. SYSTEMS

for CONVENTIONAL WINDERS - ASSEMBLY WINDERS - TWISTING MACHINES - REELING MACHINES - HANK TO CONE WINDERS - DRAW TEXTURISING MACHINES - EMBROIDERY MACHINES - CREELS, etc.

For these types of installation, Mesdan recommend the use of its hand operated splicers in combination with the exclusive A.T.S. (Air Track Supply) system.

The A.T.S. system is designed to be fitted on all kinds of textile machinery where yarn joining is necessary, thus producing a number of advantages:

#### PRODUCTIVITY

The operator can position the splicer in the optimum working position, and has the great advantage of working with both hands free.

#### SPLICE CONSISTENCY

The optimised air supply improves the splice reliability and the overall splicing results.

#### DURABILITY

Using a rail mounted unit eliminates the damage caused by falling, etc., and results is a substantial increase of the working life and in a reduction of maintenance costs.

#### HAND OPERATED JOINTAIR® FOR HANK-TO-CONE WINDERS

Because of the high number of yarn joining requested at this stage, instead of the A.T.S. system Mesdan recommend the fitting of stationary splicing units, such as JOINTAIR® 115, on alternate winding spindles.

The same solution is offered for traditional winders as an alternative to A.T.S. when a high number of joints is required.

#### TEXTILE LABORATORY EQUIPMENT

In addition to Splicers and Knotters, Mesdan manufacture a variety of instruments for the textile quality control, supplied through its MESDANLAB division.

The LAB division has profited from the vast knowledge of fibres, yarns and fabrics accumulated in Mesdan over a six decades presence on worldwide textile markets and this, coupled with the company's strong background in the design and manufacture of fine mechanisms, has placed MESDANLAB in the forefront of the most important Laboratory Equipment manufacturers.

The complete range of MESDANLAB instruments is illustrated in a specific catalogue.

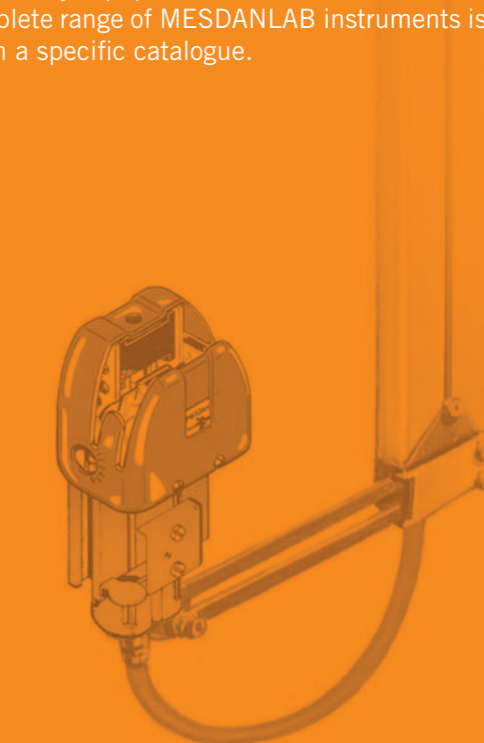

**Mesdan**

MESDAN S.p.A. Via Masserino, 6 25080 Puegnago del Garda (BS) Italy  
Phone +39 0365 653142 Fax +39 0365 651011 sales@mesdan.it www.mesdan.com



Ref. 2018/06 - Photographs and descriptions of the present leader have to be considered as purely indicative and not binding.